

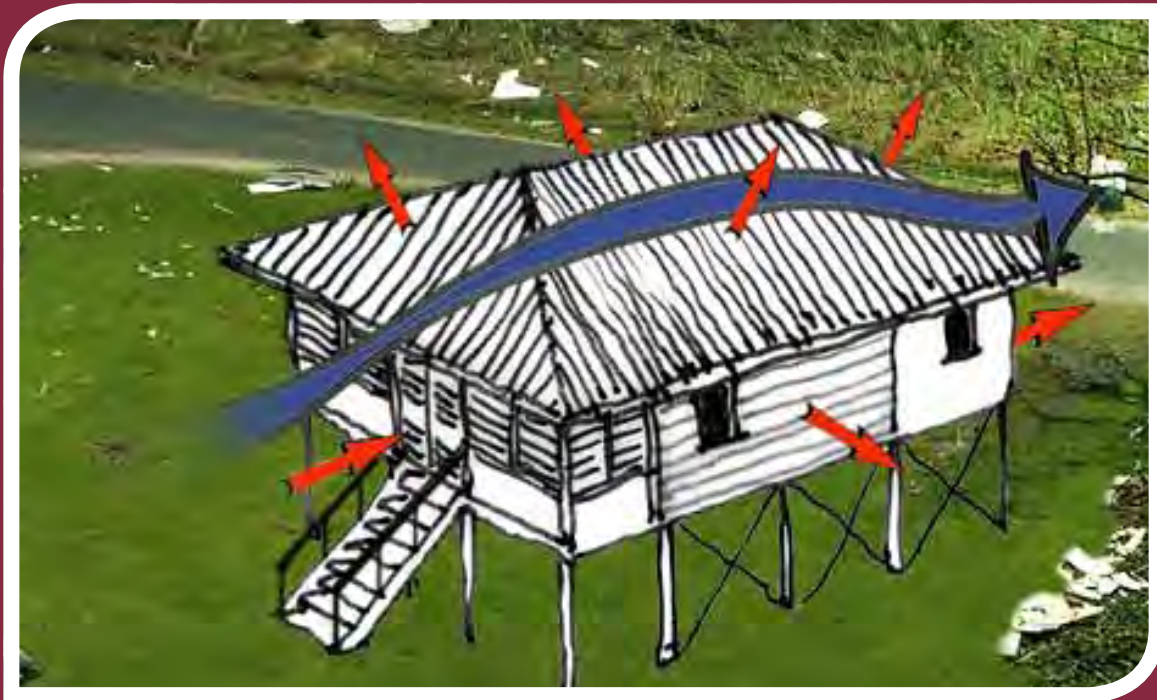

Planning for a stronger, more resilient North Queensland



Part 2 Wind resistant housing



Planning for a stronger, more resilient North Queensland

Part 1 – Rebuilding in storm tide prone areas: Tully Heads and Hull Heads

Part 2 – Wind resistant housing

Introduction

We enjoy a wonderful climate and lifestyle in Queensland. However, natural disasters such as tropical cyclones, severe storms and flooding are an inevitable part of this lifestyle. Queenslanders cannot afford to be complacent about the dangers natural disasters present.

This guideline is the second in a series - *Planning for a stronger, more resilient North Queensland* to help you and other North Queensland residents rebuild and repair your homes following Severe Tropical Cyclone Yasi (Cyclone Yasi). Many of the elements and recommendations in this guideline are relevant to any homes, new or old, in areas susceptible to cyclones particularly in raising awareness about ongoing maintenance during the dry season.

Part 1 of the series, *Rebuilding in storm tide prone areas: Tully Heads and Hull Heads*, provided recommendations on what you should consider when rebuilding or repairing your home after the storm tide event that occurred as part of Cyclone Yasi.

This guideline, *Part 2 - Wind resistant housing* provides recommendations on what you should consider to ensure that your home is repaired and rebuilt to meet current standards for wind loads associated with cyclones and other severe wind events such as thunderstorms.

This guideline focuses on ensuring that your home is better prepared for severe wind conditions and highlights hidden dangers of which you should be aware. While your home may seem protected, a thorough check will ensure that you are prepared for the next wet season. Most of the wind damage associated with Cyclone Yasi was as a result of homes not meeting or being maintained to the current design standards. Homes built to meet the current standards generally performed well. It is therefore crucial that you ensure your home meets the current standards.

The current building design provisions as required by law in Australia are based on historical wind speed data and show significantly higher design wind speeds for the cyclone regions. All houses in Queensland must be designed and constructed to these standards. You need to ensure that you are complying with these standards to ensure that you and your family and your home are as safe as possible in any future cyclone or severe wind event.

Whether you are repairing or rebuilding in northern Queensland, there is specific knowledge about the current requirements for wind loads that you should know. It is important that you ensure that any builder, designer or engineer you engage is fully aware of the existing standards for wind loads, as outlined in Appendix A of this guideline.

During a cyclone or storm, your personal safety and that of your family is paramount. You need to take steps before, during and after any of these events to help reduce potential loss of life and property damage.

In the case of a cyclone or storm event, houses built in accordance with current standards should be able to withstand their design level wind speeds, however regular maintenance before and after any cyclone season will ensure that it will continue to perform to the appropriate standards.

About this guideline

This guideline, like Part 1, has been developed to support better rebuilding and repair of homes as a result of damage caused by Cyclone Yasi, which crossed the Queensland coastline on 3 February 2011. This guideline is intended to:

- advise you as a home owner of key issues associated with rebuilding, repairing and maintaining your home as you reside in an area prone to severe wind conditions associated with tropical cyclones and storms
- provide guidance to assist in ensuring design outcomes are compatible with the tropical climate, the character of the area and the needs of the residents
- outline the approvals process including building certification.

Objectives

The main objectives of the guideline are to:

- improve the resilience of residential dwellings to the impact of severe wind conditions predominately caused by a tropical cyclone
- assist in safeguarding property in a severe wind event by outlining the current codes and standards for wind resistance to ensure your house, and any building or structure that you might own, meets the current standards
- improve the broader long term sustainability of dwellings and communities.

Existing design standards for housing

In Australia we have comprehensive building standards to enable buildings to resist wind loads. This work has evolved over many years and has resulted in a very good understanding of effective house design to resist severe thunderstorms and tropical cyclones.

During Cyclone Yasi, homes built to the current wind load standards generally performed well. So in repairing and rebuilding after wind damage, it is important that the current codes and standards are followed. This will give your house the best chance of performing well and safeguarding the lives of you and your family during these types of events in the future. It is, however, important to remember that while your home may seem okay, you still need to check for hidden dangers especially after the winds that were experienced during Cyclone Yasi.

This guideline provides relevant information to assist you to ensure that repairs and rebuilds meet the current standards which should provide protection during any future severe wind events. Any rebuilding or repair work must comply with all aspects of current codes and standards.

Many of the elements and recommendations in this guideline are relevant to any homes, new or old, in areas susceptible to cyclones particularly in raising awareness about ongoing maintenance during the dry season.

You need to ensure that your contractor is aware and understands mandatory design standards for wind loads as required by current Australian law.

1 Understanding Cyclones

What is a Cyclone?

Tropical cyclones are low pressure systems that develop over warm oceans in the tropics and can affect tropical and subtropical regions of Australia. They produce very strong winds rotating clockwise around a calm centre. Very strong winds, heavy rainfall with flooding and storm tide are all elements of a tropical cyclone.

Strong winds generated during severe tropical cyclones can cause extensive property damage and turn wind-borne debris into missiles. Tropical cyclones can also produce heavy rainfall over extensive areas that can cause further damage to property and infrastructure and potential injury and loss of life. As well, the low central pressure and strong winds over the ocean can lift the sea water surface to produce a storm tide and this effect is covered in Part 1 of these guidelines.

Categories of cyclones

The severity of a tropical cyclone is described in terms of the Australian Cyclone Severity Scale. This five-category system is based on the wind speeds generated by the cyclone. The Bureau of Meteorology quotes wind speeds measured under standard conditions – at a height of 10m above the ground and measured in flat, open terrain (similar to that at airports). The wind speeds measured under standard conditions can be different from those at house sites even in the same area, as the wind speeds at house sites are affected by the proximity of buildings and topographic landscape features.

The following table presents maximum expected sustained winds and estimated wind gusts near the centre of a tropical cyclone measured under standard conditions. The Bureau of Meteorology uses a 10 minute averaging time for reporting the sustained winds. By comparison, gusts are a wind peak lasting for just a few seconds.

Cyclone category	Estimated sustained wind speeds (km/hr)	Strongest gust (km/hr)	Typical effect (indicative only)
1	63-88	Below 125	Tropical cyclone causing negligible house damage. Damage to some crops, trees and caravans. Watercraft may drag moorings.
2	89-117	125-164	Tropical cyclone causing minor house damage. Significant damage to signs, trees and caravans. Heavy damage to some crops. Risk of power failure. Small watercraft may break moorings.
3	118-159	165-224	Severe tropical cyclone causing some damage to roofs and structural damage on older houses. Some caravans destroyed. Power failure likely.
4	160-199	225-280	Severe tropical cyclone causing significant roofing loss and structural damage on older houses. Many caravans destroyed and blown away. Dangerous airborne debris. Widespread power failures.
5	Over 200	Above 280	Severe tropical cyclone. Extremely dangerous with potential for widespread destruction.

Source:- www.bom.gov.au/cyclone/faq/

Wind classification of a house

Every house in Australia can be wind-classified based on the wind region and site conditions (Figure 1). In Queensland, the coastal areas to the north of the state are in wind region C and the design wind event in a severe tropical cyclone. The design gust wind speed for housing in these areas is approximately 250 km/hr (related to standard measurement conditions – height of 10 metres above the ground in flat, open terrain). Because most houses are not built in flat, open terrain similar to airfields, a modified design wind speed needs to be calculated for each house based on the expected standard wind speed for the house site.

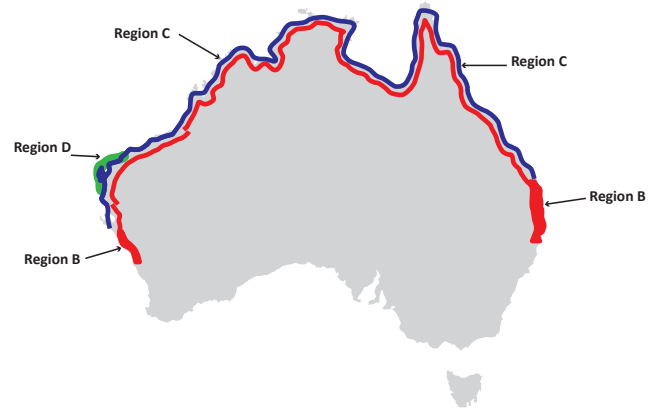

Figure 1 – Cyclone Regions as identified in AS1170.2-2002 Wind load standard

For houses built in cyclonic wind regions C (the majority of coastal Queensland), there are four wind classifications: C1, C2, C3 and C4. A house with a higher classification number means that the wind speed at the site will be higher than that for a house built somewhere else with a lower classification ie a C4 house should be stronger and more resistant to winds than a C1 house.

Three site conditions are used to establish the wind classification of a house: (a) the roughness of the surrounding landscape and terrain, (b) its topography and (c) the density and proximity of obstructions of similar or bigger size to that of the house. The wind classification relates to the wind speed expected at the roof level of the house given a design wind speed measured under standard conditions. In Region C of Queensland, the design wind speed is 250 km/hr wind.

Wind classification	Design gust wind speed	
	m/sec	km/hr
C1	50	180
C2	61	220
C3	74	266
C4	86	310

Relationship between the wind classification and design wind speed. As houses are affected by each gust in the wind stream, it is the gust wind speed that is used in design and all wind speeds in the rest of the guide refer to gust wind speeds.

Houses built on hillsides, especially near the top of hills where very little shelter exists, are subjected to stronger winds than houses built on flat terrain that may be shielded by neighbouring buildings of a similar or bigger size. Houses located on unobstructed terrain including those facing the sea, or on the edge of a golf course or in a large field are also susceptible to stronger winds.

The following plot (Figure 2) shows the difference location can make. For a given event, the houses on a hill top can experience three times the wind forces of those in flat locations. The design wind speed at each site is derived from a single design wind speed of 250 km/hr. Once the wind classification of your house is known, you will be able to readily determine the wind forces that your house should be built to withstand.

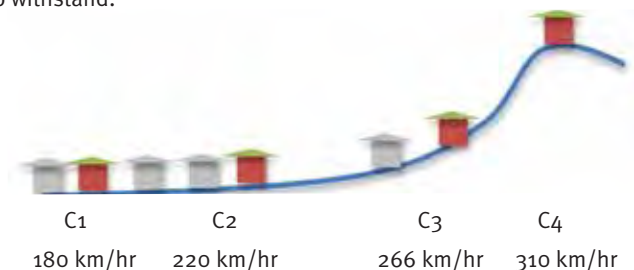

Figure 2 – Design wind speed

2 Key considerations

In understanding Cyclone Yasi it is important to understand the ocean conditions at the time when Cyclone Yasi formed.

Signs of a developing La Niña emerged during autumn 2010 as the Western Pacific ocean cooled rapidly at the end of the 2009-10 El Niño. La Niña events are usually associated with above average rains in many parts of Queensland during the wet season and more cyclone activity than normal.

By July 2010, La Niña conditions were established and most of Australia experienced significantly higher than average rainfall over the next eight months. The Bureau of Meteorology predicted in its Seasonal Outlook that the 2010/2011 summer would be a very active cyclone season due to the effects of La Niña.

Peaking between late 2010 and early 2011, this La Niña event was one of the strongest recorded since the late 1800s. Record high rainfall across much of northern and eastern Australia during this event, lead to widespread flooding in many regions between September 2010 and February 2011.

This event saw Australia experience its wettest September on record, the wettest “dry” season on record in northern and central Australia, and the wettest summer on record in Victoria. The calendar year 2010 also ranked as Australia’s second wettest year on record with September and December the wettest on record.

Cyclone Yasi, possibly the strongest cyclone to make landfall in Queensland since the strong La Niña event of 1918, crossed the coast between Cairns and Townsville on 3 February 2011.

Cyclone Yasi wind speeds – can they happen again?

Estimates of the gust wind speed in built up areas surveyed following Cyclone Yasi suggested that they were marginally less than the current design wind speed for housing in these areas. On its approach to the coast, the Bureau of Meteorology classified Cyclone Yasi as a marginal Category 5 event and the significant damage to Bureau facilities on Willis Island showed that it had extremely high wind gusts off shore. The Cyclone Testing Station used damage to simple structures to estimate wind gust speeds near building sites in the coastal region between Innisfail and Ingham and these studies showed maximum gusts in the worst affected areas of 240 km/hr (see Figure 3). Homes in the area in which Cyclone Yasi hit, are required under a current standard to withstand winds at 10m in flat, open country (standard conditions) of approximately 250 km/hr.

The current codes and standards should provide adequate structural performance to houses under wind loads for these events; hence houses constructed and maintained to these standards should provide safe refuge from the wind in tropical cyclones with the same intensity as Cyclone Yasi. However, where your house is also in a storm surge zone, early evacuation remains the single best way to protect life during a storm tide event even if your house has been properly constructed and maintained to resist wind.

The gust wind speeds shown in Figure 3 are estimates based on assessment of wind loads on simple structures and modelling of the wind field. There are uncertainties associated with these estimates in the order of +/- 10 per cent. The gust wind speeds are referenced to 10m height in flat open terrain. To convert these speeds to site gust wind speeds for individual houses, factors that account for hills, shielding, height etc need to be applied for the specific site. (Reference Cyclone Testing Station Technical Report TR57). Using these factors, each house would have experienced an actual gust wind speed marginally less than the design wind speed.

While unlikely, there is a low but finite probability of the same or higher wind speeds again occurring within the life of your home. The wind gust speeds in Cyclone Yasi have a less than 10 per cent chance of occurring within any 50 year period at any location within Queensland’s cyclone region.

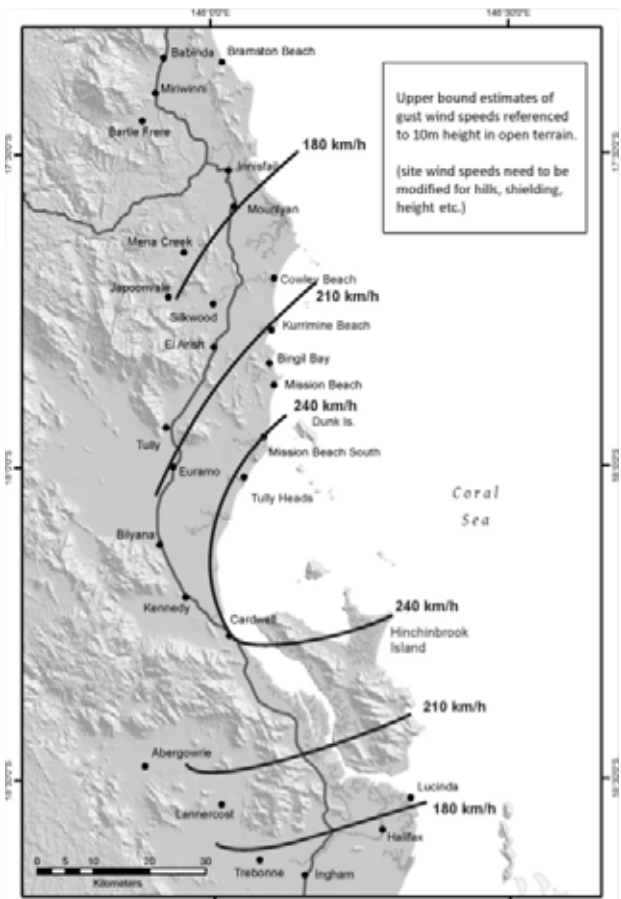

Figure 3 –Estimates of gust wind speeds in standard conditions (10m height in flat, open country). Map courtesy of the Cyclone Testing Station, James Cook University.

‘Risk-based’ design

Tropical cyclones have a range of strengths and sizes and there is no way of accurately predicting the worst wind speed that will occur in the life of any house. However, historical records have been analysed and studies of cyclone formation and movement have been used to predict the probabilities of occurrence of severe wind events in the future.

These studies have given an implied level of risk of wind damage for all locations in Australia. There is a small chance that the design wind speed will be exceeded during the life of some structures and there is no way of knowing whether it will be early in its life or later (or happen more than once). However the consistent level of risk adopted throughout the country means that all new buildings have a very good chance of sustaining no damage from the more frequent wind events and a reasonable chance of surviving even the rare events. However, it should always be remembered that there may be some events that exceed the design wind speed.

Climate Change considerations

It is difficult to assess what the medium term effects of climate change on wind speeds are likely to be. However, within the life of houses that are built or repaired now, the probability of occurrence of the current design wind speed will remain much the same for the each of the various current climate change scenarios.

Housing designed and built to the current standards will be appropriate for wind speeds in climate change predictions for the next few decades.

Therefore it is recommended that all housing designs meet at least the current standards for wind design to minimise the potential of any significant damage from future events.

3 Understanding wind loads

External wind pressures

As wind passes around a building, it applies pressure and suction to all external surfaces of the building.

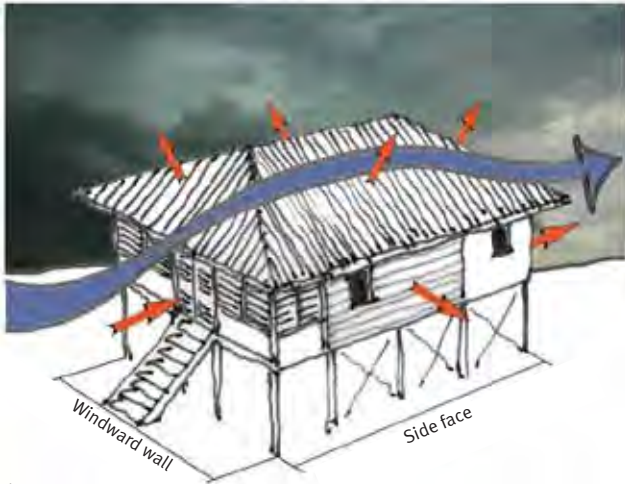

Figure 4

Figure 4 above demonstrates the external windward wall that is facing the approaching wind. The windward wall is unique as it applies pressure that tends to push that surface inwards. All other surfaces generally have suction on them tending to pull that surface outwards. These pressures act directly on the cladding material and are transferred to the structural elements underneath them. All of those forces must be carried successfully by elements in the structure all the way to the ground.

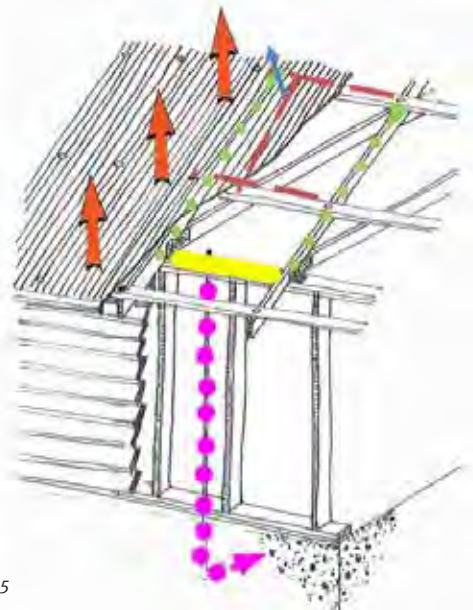

Figure 5

Figure 5 above shows the wind pressure at one location on the roof indicated by the blue arrow being transmitted up and down the roofing by the red line, then into the roof batten through the roof fasteners and sideways through the battens as illustrated by the red lines. The forces are transferred to the rafters by the batten fasteners and the rafters carry the loads to the wall plates illustrated by the inclined green lines. The rafters transfer their loads to the top of the wall where it is carried to the tie-down rods as shown by the horizontal yellow line. The tie-down rods carry the loads to the footings as shown by the vertical pink line.

Internal wind pressures

In tropical cyclones, the sustained winds over a number of hours can cause windows, doors or cladding to open. Where this happens, some of the external pressure can be transferred to the inside of the building through the opening (Figure 6). These openings can be caused by wind-borne debris which can break windows or doors and in some cases can fracture wall cladding. They can also be caused by failure of door and window latches or hinges, or simply by having a door or window left open at the time of the cyclone.

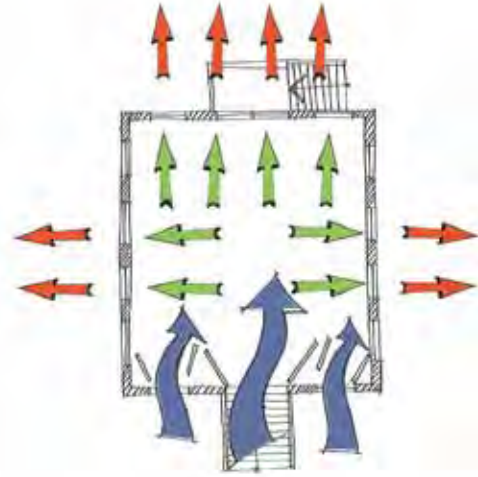

Figure 6

Where the opening is created on a windward wall by windows or doors breaking under either wind pressure or debris impact, the opening will allow the building to have higher internal pressures (Figure 7). The higher internal pressures push upwards on the underside of the roof and this effect adds to the upward forces caused by suction on the external roof surfaces. Hence all roof elements should be designed for the higher forces that come from the addition of internal pressures and external suction. Under these circumstances, all surfaces other than the windward wall surface have to resist higher loads as a result of an opening on the windward wall.

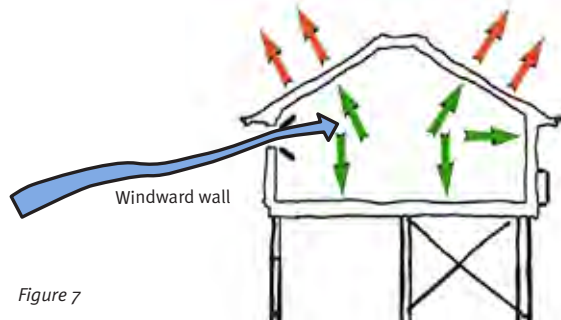

Figure 7

Where the opening is on any other surface (Figure 8), then the air inside the building will have a low pressure and will cause suction on all internal surfaces. This combines in an adverse way with the external pressure on the windward wall and significantly increases the load that must be resisted by the windward wall and any structural elements (eg windows) in that surface.

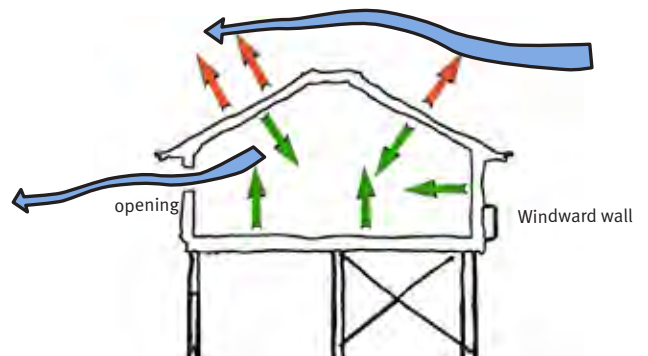

Figure 8

Wind loading standards

There are two wind load standards that can be used in the design of houses in Australia and these are the standards that you need to ensure that your designer and builder are aware of:

- AS/NZS1170.2 – Design actions, Part 2 wind actions. This is a general wind load standard that can be used for most types of buildings and all houses regardless of size.
- AS4055 – Wind loads for houses. This is a standard that can only be used on houses that are within some geometric constraints.

Most houses can be designed using wind loads found from AS4055, but where they are particularly big (e.g. three storeys or very large plan area), they will fall outside the scope of AS4055 and AS/NZS1170.2 must be used.

Where wind loads are evaluated using AS4055, the internal pressures used take into account the additional loading from dominant openings. However where using AS/NZS1170.2 appropriate pressure coefficients must be selected to model these openings. It is very important that your building designer, architect or engineer uses the correct standard when designing your house.

Site wind speed

All structures designed in accordance with the standards should resist the wind likely to be expected at the site. The design wind speeds are a function of the location and exposure of your house. Some factors that may give a particular site high exposure include absence of shielding buildings close proximity to open water, large parks, or open fields and elevated topography. These factors are taken into account in both AS4055 and AS/NZS1170.2.

A rough guide as to the degree of exposure can be related to the view from the site.

If you can only view adjoining houses from your site, it often indicates a low exposure site. If you have a view over or past the surrounding houses this will probably indicate a medium exposure site. A view over the surrounding suburb or neighbourhood will often indicate a high exposure site.

Most house sites are categorised using wind site classifications given in AS4055. The following are most common classifications for cyclonic regions in Queensland:

- C1 is used only for low exposure sites, with good shielding and no view.
- C2 is the most common classification and appropriate for low exposure.
- C3 is used for medium exposure sites.
- C4 or above is used for high exposure sites.

Make sure that you know what classification has been used for your house and that it is marked on the plans or contract prior to construction. The design wind speeds or site classification have a large effect on the wind loads that your house must resist during a cyclone. Houses in more exposed locations must be designed to resist larger wind forces.

Effects of wind actions

Where houses were designed and built appropriately to resist the wind forces and the structure was able to withstand wind in Cyclone Yasi, some minor debris damage may have occurred despite the building withstanding this severe event. However, some combinations of design or construction errors or omissions may have contributed to wind damage. The photos on the right track the important connections on the load path from the roofing to the ground.

Photos provided courtesy of the Cyclone Testing Station, James Cook University.



Photo 1 – roof has resisted loads near the design wind load in spite of minor debris damage and roller door failure



Photo 2 – roofing fasteners not installed in accordance with manufacturer's recommendations



Photo 3 – inadequate batten to rafter connections (common in older housing)



Photo 4 – inadequate roof truss anchorage



Photo 5 – inadequate tie-down through the entire structure

Roof

Roller door

Roofing

Batten connections

Roof structure tie-downs

Roof and walls

4 Strategy for repair, rebuilding, maintenance to resist cyclone winds

The Building Code of Australia requires buildings to be designed and constructed to resist the design wind forces. This means that all cladding, windows, doors and garage doors must be built to resist the possible combinations of design wind pressures at the design wind speed. It also requires all structural elements to be designed and constructed to resist the wind pressures.

All building work (repair or new construction) should be undertaken by licensed trades people. Building work may also need a building approval and you may check whether this is the case for your house with a building certifier or council or the Building Services Authority.

Site design wind speed or classification

Whether the job entails repairing or rebuilding, the first step is always to determine the wind classification of your house site:

- Where the house complies with the scope of AS4055, then the wind classification will be C1, C2, C3 or C4. (An amendment has been proposed to AS4055 that will use the maximum slope of a hill or ridge to determine the topographic class of the site and it is recommended that this be used in practice).
- In all other cases, AS/NZS1170.2 is to be used and will result in site design wind speeds. These are then used to determine wind pressures assuming a dominant opening on the worst surface for each building element.

The site wind classification or wind pressures should then be used to specify the required performance for all structural elements of your house.

Building

When selecting building elements, consideration should be given to wind classification and pressures to determine suitability. This includes external wall and roof cladding, windows, doors, garage doors and soffits.

It is important that each component of your house is matched to the wind requirements for the site. Higher exposure sites will require elements that have a higher wind rating. Loads on building elements are also a function of their location in the building. In cyclone areas it is not possible to predict whether an element will be on a windward, leeward or side face, so all elements must be able to perform regardless of the wind direction. However, their location on a wall can make a difference. For example when ordering doors or windows for houses, it is necessary to indicate the wind classification and whether or not the element will be close to a corner of the building.

Building structure

All of the building's structural elements provide a load path to resist the wind forces on your house and transmit them to ground. Each connection in your house structure will be required to resist wind forces when the wind is coming from one or more directions. Assistance from an appropriately qualified person should be obtained for specification details and supervising building work.

Footings

Footings provide the link between your house and the ground. Footings transmit lateral forces and should be designed to have sufficient weight or embedment to resist uplift forces.

Sheds

Sheds are often very light, yet have substantial wind loads. This means that they must be fastened together securely and anchored to a footing system that can resist the substantial uplift loads. If you have a shed, it is vital that it is designed to the correct wind loads and is designed for internal pressures that may result from an opening after failure of windows or doors.

All components of sheds – doors, windows or roller doors – must also be specified using the site wind speed.

Ancillary items

Many ancillary items including fences, guttering, vegetation and water tanks are also subjected to significant pressures in cyclonic winds. They should all be detailed to reduce the potential for damage to those items or to other buildings if the ancillary items become wind-borne debris that may damage your or your neighbours' homes.

It is very difficult to design cost-effective fencing that can resist the lateral forces of wind loads. However, it is possible to design the base of fence posts so that if they fail, they still remain attached to the ground. In this way if your fencing fails during a cyclone event it does not become wind-borne debris and will still be fastened to its footings.

Guttering is not normally considered a structural element and can fail in tropical cyclones. The cost of its repair can prove substantial where scaffolding is required and the lost guttering can become wind-borne debris. However, increasing (doubling) the number of guttering clips will greatly improve its wind resistance.

Full water tanks have sufficient weight to resist the wind forces on most tanks. However, empty or partially full tanks can fail by deformation of the tank itself or by overturning of the complete tank. Tank stands and footings should be appropriately designed and constructed for these severe wind loads. It is best to make sure that your tanks are full before the approach of any cyclone.

Buildings in storm tide zones

If you live near the sea, other features of your house should be planned for to avoid the effects of storm tide. Part 1 in this series provides information on the construction of houses located in storm tide prone areas. The measures in Part 1 should be applied in addition to the recommendations of this guideline.

Where construction is in a storm tide prone area, it is recommended that all metal components are well protected against corrosion. This should be considered for both exposed and hidden components.

In cyclone areas it is not possible to predict whether an element will be on a windward, leeward or side face, so all elements must be able to perform regardless of the wind direction .

✓ Repair of houses damaged by Cyclone Yasi

Where part of your house has been damaged, there are some basic principles for the repair of the building:

- Where elements have failed due to their own weakness, it is recommended that they be replaced with stronger elements. Where the damage was caused by wind forces rather than by direct debris attack, then it indicates a systematic problem with some elements of your home. If the elements are replaced with similar ones, then your repaired house may have the same weaknesses built in. One way to improve the resilience of your home to future cyclones and to reduce the liability for the owners and insurers is to ensure that the building repairs are to an appropriate standard.
- Where damage exposes weaknesses in the structure, all such weaknesses should be replaced whether they failed during Cyclone Yasi or not. Where the wind forces damaged only some elements of your house, but the same elements are repeated through the rest of the building, then the remaining elements may be susceptible to damage in future events unless they too are upgraded. Your repaired house will only have improved resilience if all of the weak details are improved. Remember that the wind direction may be different for another severe cyclone event.
- Check and upgrade the whole structural system if part of it is damaged. The loss of part of your house structure may have meant that lower elements in the building were not subjected to the full load in this event. If the damaged elements are replaced with stronger ones, but the elements lower in the structure are left unimproved, then the weak link may have been moved lower in the building. It is important to ensure that all elements have the required capacity to perform in future events.

The Yasi summary according to BoM



Severe Tropical Cyclone Yasi began developing as a tropical low north west of Fiji on 29 January 2011 and started tracking on a general westward route. The system quickly intensified to a cyclone category to the north of Vanuatu and was named Yasi at 10pm on the 30 January 2011 by Fiji Meteorological Service. Yasi maintained a westward track and rapidly intensified to a Category 2 by 10am on 31 January 2011 and then further to a Category 3 by 4pm on the same day.

Yasi maintained Category 3 intensity for the next 24 hours before being upgraded to a Category 4 at 7pm on 1 February. During this time, Yasi started to take a more west-southwestward movement and began to accelerate towards the tropical Queensland coast.

Yasi showed signs of further intensification and at 4am on 2 February was upgraded to a marginal Category 5 system. Yasi maintained this intensity and its west-southwest movement, making landfall on the southern tropical coast near Mission Beach between midnight and 1am on Thursday 3 February. Being such a strong and large system, Yasi maintained a strong core with damaging winds and heavy rain, tracking westwards across northern Queensland and finally weakened to a tropical low near Mount Isa around 10pm on 3 February.



Map Legend: ■ Very Destructive Winds ■ Destructive Winds ■ Gale Force Winds

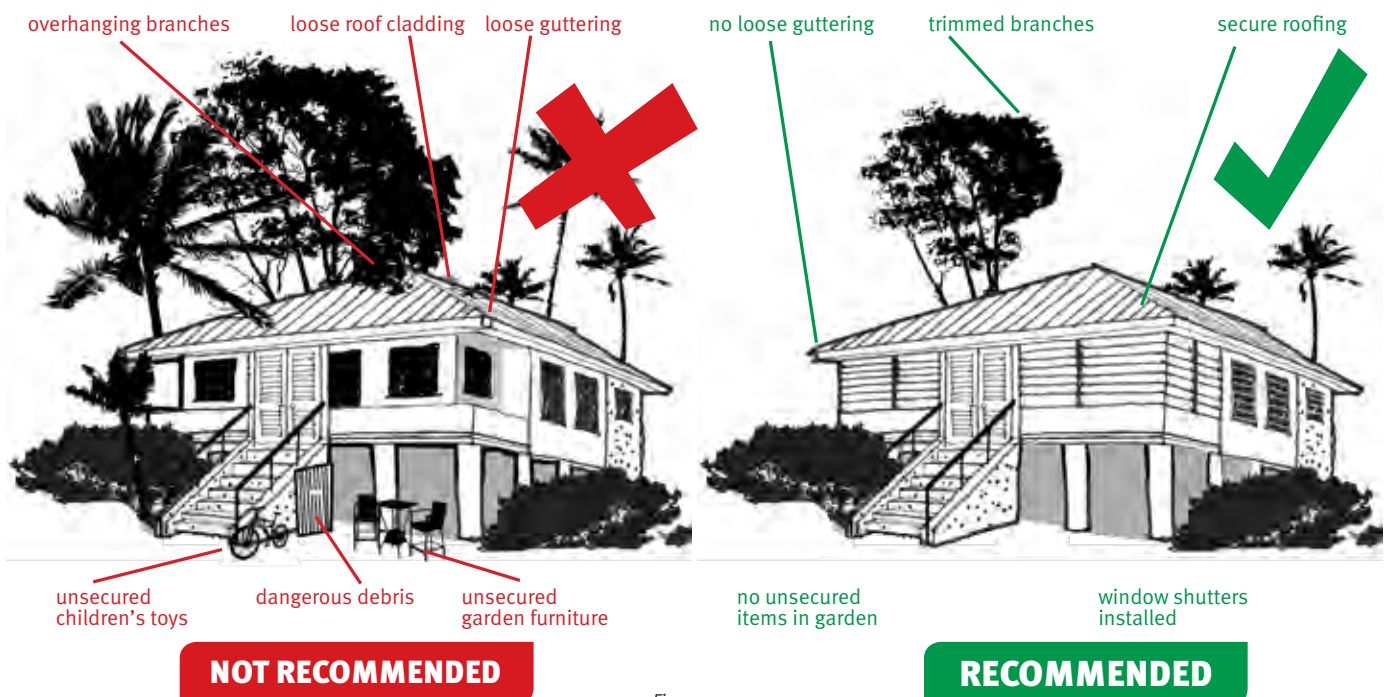

Figure 9

5 Building components

Materials selection

Building products used in cyclone regions need to be fit-for-purpose. Not only must they withstand wind loads but issues of weathering/durability (or loss of strength from eg UV degradation, corrosion, rusting and timber rot or termite attack).

Products that are part of the structural fabric of the house (including roof and wall cladding, windows, skylights etc) should be selected by considering manufacturers' data to show that their products have passed tests to relevant standards and are suitable for use in North Queensland.

Care needs to be taken in the selection of metallic components for your house (including nails) where the building is sited either within 500 metres of the high tide line or in a storm tide zone. Either heavily galvanised steel or stainless steel elements should be used in accordance with manufacturers' specifications and maintenance should be scheduled to check their condition regularly.

The Building Code of Australia requires buildings to be constructed to prevent water entry. However, in a tropical cyclone, water may enter the roof space and be driven into your house through windows, doors and other flashing elements. Where possible, you should select materials that can sustain some wetting and drying without deterioration. This will mean that future events will not require substantial work to address water ingress issues.

For houses in low exposure areas (C2 sites), you can select appropriate elements using Department of Local Government and Planning (DLGP) - Growth Management Queensland publication *Repair of sheet metal roofs in cyclonic areas*. But for other wind classifications, details can be sourced in AS1684.3:2010.

Review to DLGP website link – www.dlgp.qld.gov.au/resources/guideline/building/floods/repair-roof-after-cyclones.pdf

Installation

Just as it is important that the correct details are selected for each element in the load path, it is equally important that they be correctly installed. This entails the use of the right connectors, the correct number of nails or screws, and correct placement of fasteners. Building standards such as AS1684.3 to be followed. The appropriate elements and product installation guidelines need to be followed.

Regardless of the age of your building there are building standards to ensure your roof can withstand the design level cyclonic winds.

Roof cladding

Roofing systems (e.g. metal cladding or concrete tiles) are subjected to large fluctuating uplift forces tending to pull the roofing off the building during a cyclone. These forces are well in excess of the weight of the roofing, so fasteners are needed to hold the roof on the building. For metal cladding, screws are usually used to secure the cladding to the battens below. For concrete tiles, each tile should be secured to the batten by a clip or fixing.

There are hundreds of roof fasteners in a single house and each one is important in keeping the roof on.

Roof battens

Roof battens must be anchored to the rest of the structure well enough to carry all of the forces from the cladding. Neglecting to anchor roof battens to the rest of the structure is a common weakness in older houses. If your house was built prior to the 1980s it is important that you get either a builder, engineer or building certifier to carefully check that the batten to rafter connections are strong enough to carry future wind loads.

Guidelines for the retrofitting of older timber constructions are given in HB132.2 Structural upgrading of older houses – part 2: cyclone areas.

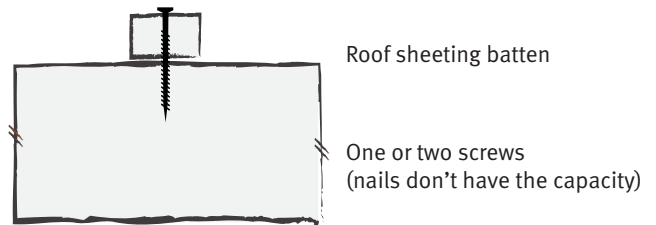

Figure 10

For houses in C2 wind classification areas (low exposure), the battens can often be secured by two No 14 Type 17 screws, provided the spacing of battens is close and within 1200 mm of the edges of the roof. For C3 classified houses (medium exposure), straps or framing anchors must generally be used to deliver the higher strength required by the higher wind exposure sites.

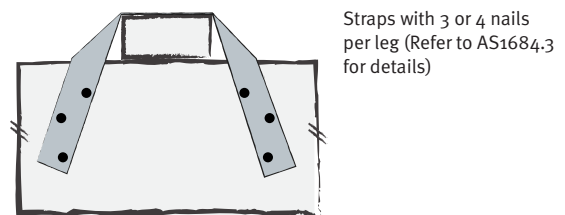

Figure 11

Rafters or trusses

The rafters and trusses themselves need to be designed to be appropriate for the wind classification. In the case of prefabricated trusses, the supplier will need to be given the wind classification in the specification. Rafters can be sized using AS1684.3:2010.

The tie-down of the trusses or rafters to the rest of the structure needs to be sized for the wind classification, spacing of trusses and span of the trusses. It is particularly important to recognise that girder trusses have significantly higher tie-down requirements, so their anchorage must be much stronger.

There are many different acceptable details for anchorage of trusses and rafters including bolted metal brackets between the wall and the truss, thin metal straps over the trusses or U shaped bolts that go over the trusses. In some cases over-battens have been used to hold down trusses.

Tie-downs

A typical house structure relies on multiple continuous chains of tie-down elements: from the roof cladding, through battens, trusses or rafters, into the walls, down through the walls and into the subfloor structure including the footings.

Tie-down rods in timber framed construction and steel frame elements transmit uplift forces from the roof down through the wall structure and eventually to the ground.

Wall systems must be correctly anchored to the subfloor including concrete slab for slab-on-ground construction. Particular care is needed at the sides of openings as higher forces can be transmitted there.

The required anchorages for your house are determined by the wind classification and the area of the structure that contributes load to the building element. Some alternatives are given for each element in the tie-down system in AS1684.

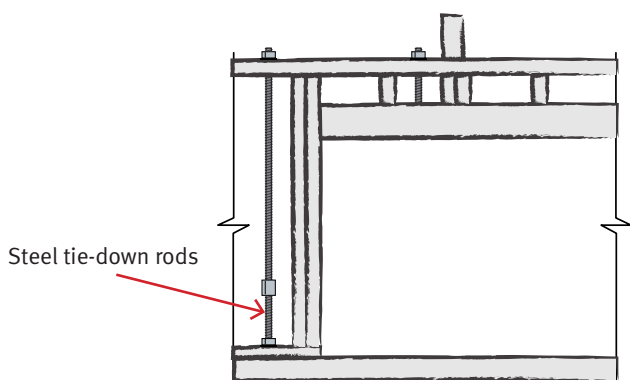

Figure 12 – A common method for tie-down through timber framing

Because the weight of all of the elements in the tie-down chain helps to resist the uplift forces, the net uplift force decreases as elements are deeper in the structure. However, for most houses, you should be able to trace tie-down elements that carry the forces from the roof all the way to the footings and ground below.

Bracing

Wind pushes on the sides of your house and unless there is adequate bracing in the structure of the house, the top can move relative to the bottom of the house. The total force to be resisted by the bracing is a function of the face area of the house above the lateral bracing. Unlike the uplift forces discussed above, the lateral forces on a house increase the further down the structure you go. Hence the lateral bracing at or below floor level has the highest forces applied as it has the full area of the house to attract the load.

Bracing elements in the walls are required to transmit lateral load from the roof level to the floor. On houses built above the ground, bracing elements between the floor and the ground are required to transmit the lateral forces to the ground.

Bracing can be provided by shear panels such as plywood and plasterboard or by cross bracing elements such as steel straps or timber members.

AS4055 has a section that provides methods for calculating the bracing resistance required. Methods for providing the resistance are detailed in product standards and manuals such as AS1684 for timber framing.

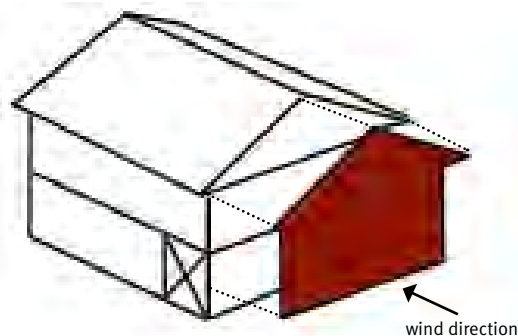

Figure 13 – Bracing panel to resist the shown wind forces

Wall cladding

External wall cladding must resist wind forces and may be required to resist debris impact. Resilient cladding that can absorb the impact of small to medium-sized debris works best.

Internal wall cladding may be required to contribute to the bracing strength of the building and also has the potential to get wet in a cyclone. Small amounts of moisture may be blown inside the building, but where some flashing or a window or door fails, it is possible for substantial amounts of water to enter into the building. Less repair work is required where wall and ceiling linings do not deteriorate when wet, so the choice of resilient building materials is very important.

Windows and doors

Your windows and doors form part of the building and need to resist the wind pressures for both positive pressure (windward wall) and suction (leeward and side walls).

Damage investigations from Cyclone Yasi revealed some windows that were not properly installed were blown into (or sucked out of) houses due to lack of or inadequate fixings of the frames to the house structure. Glass panels also need to be correctly sized for the wind loads and the window or door frame also must be adequately fixed to the rest of the building.

Standard entrance door locks with simple striker plates into the door jamb may not be adequate to resist cyclonic wind loads. Additional support for external doors (eg barrel bolts or dead locks etc) may be required.

The Australian Window Association gives the correct number of nails/screws to be used. The guide is available from AWA website www.awa.org.au.



Photo 6 – Damage to door lock after high winds.
Source: Cyclone Testing Station, James Cook University.

Garage doors

One of the common failures observed in Cyclone Yasi was disengagement of roller doors from their tracks. This left the door free to flap in the opening and allowed wind and water to enter the garage and in some cases the house. On some buildings, the change in internal pressure caused other damage to the structure. Failure through buckling of sectional doors was also observed.

When reinstalling a garage door, you should ensure that doors that are specified to resist the design wind speed for your house location. These doors may have wind locks or other braces to help resist the wind loads. The wind locks transfer additional load from the ends of the roller doors into the tracks and then into the wall. The walls need to be strengthened to resist this additional load.

Debris protection

Because tropical cyclones cause very high winds over a sustained period (several of hours), debris that may have come from failures in other buildings or from trees or from other materials, is picked up by the wind and may crash into your house.

There are some things that you can do to improve the debris resistance of your house. Installing debris screens on the windows can absorb the impact of debris and lessen the chances of windows breaking during a cyclone. Preventing windows from breaking will then reduce the amount of water that is blown into the house. Debris screens can be permanently fixed screens that may double as security screens or can be specially fitted before the arrival of the cyclone. Temporary screens can be as simple as sheets of plywood securely fastened across the window.

Some debris observed after cyclones can be very large (eg whole roofs). Large debris is likely to exceed the capacity of most screens and may damage external walls. Impact from large debris increases the risk of harm to people that are sheltering in the house. However, by ensuring that the small rooms in which people will shelter during a cyclone are strengthened, the risk to occupants can be reduced. Incorporating plywood and/or sheet metal in the walls and ceiling linings of those rooms will strengthen them for impact, uplift and racking, providing a strong compartment for emergency shelter.

When reinstalling a garage door, ask for doors that are specified to resist the design wind speed for your house location. These doors may have wind locks or other braces to help resist the wind loads.



Photo 7 – Roller doors damaged after being hit by high winds.
Source: Cyclone Testing Station, James Cook University.



There have been 214 reported impacts from tropical cyclones along the east coast of Australia since 1858. Tropical cyclones that have significantly affected communities include:

- 1890 Cardwell
- 1893 Brisbane
- 1898 NSW
- 1899 Bathurst Bay
- 1918 Innisfail
- 1918 Mackay
- 1927 Cairns and inland areas
- 1934 Port Douglas



Mackay 1918
Source: John Oxley Library, State Library of Queensland.



Mackay 1918

The convention of naming Australian tropical cyclones began in 1964. The first Western Australian named cyclone was Bessie that formed on 6 January 1964. Female names were used exclusively until the current convention of alternating male and female names commenced in 1975.

6 Approvals

Why building approval is needed?

In Queensland, it is a requirement to obtain building approval prior to commencement of building works other than for minor repairs. Building approvals are required to set standards in the structural requirements of buildings and the safe and appropriate use of materials during construction. These standards represent a means of protecting the public's health and safety, welfare of the structure and its surrounds and allow for councils to implement a standard of construction they want to see practiced within their boundaries.

Exemptions from obtaining building approval only apply for minor structural work where the work does not affect more than 20 per cent of the building's structural components of the same type. Owners and occupiers should also take steps to find out whether their building's fire safety installations have been damaged or affected by wind damage before allowing the building to be re-occupied.

Difference between planning and building approval

Planning and building approvals deal with different issues in the construction process. Generally, planning approvals determine what uses and activities can occur on the land to minimise any potential impacts on surrounding properties. Building approvals ensure buildings are constructed to standards that address health and amenity, safety (structural and fire) and sustainability.

An application for planning approval is assessed against a council's planning scheme, whereas an application for building approval is assessed against a set of building provisions including the Building Code of Australia and the Queensland Development Code.

Building Approval Process

The normal building approval process will apply when seeking approval to commence construction. A building approval will need to be granted by a building certifier and/or council. The certifier will need to confirm the proposed building complies with the relevant building codes and standards before any construction begins. Building certifiers are required to inspect that the work is being constructed to the relevant codes and standards.

Buildings in areas prone to cyclones and severe wind events are recommended to be designed in accordance with this guideline and the relevant Australia Standards. However, it is important to note that in some individual circumstances this document could conflict with provisions under the *Building Act 1975*, such as siting requirements. In these cases, the requirements of the *Building Act 1975* will prevail over this guideline. It is recommended that you and any builders you engage check with your building certifier or local government for clarification of the requirements for your individual circumstances.

Further information regarding the approvals required to rebuild should be sought from your relevant local government.

It is recommended that you ensure that all building designers, architects and contractors that you engage are aware of the issues raised in this guideline.

Other useful contacts include:

Building Codes Queensland, freecall 1800 534 972

www.dlqp.qld.gov.au/our-services/building-codes-queensland-2.html



Photo 8 – Cardwell foreshore storm damaged after Cyclone Yasi.



Photo 9 – Cardwell foreshore repaired after Cyclone Yasi.

Disclaimer: This publication contains or refers to factual data, analysis, opinion, references to legislation and other information (together Information). The Queensland Reconstruction Authority and the State of Queensland make no representations and give no guarantees or warranties regarding the accuracy, completeness or suitability for any particular purpose of such Information. You should make your own enquiries and take appropriate advice on such matters. Neither the Queensland Reconstruction Authority nor the State of Queensland will be responsible for any loss or damage (including consequential loss) of any kind howsoever arising that you may suffer from using or relying upon any of the Information. By using or relying on any of the Information you agree to indemnify the Queensland Reconstruction Authority and the State of Queensland against any loss or damage arising out of or in relation to your use or reliance.

Appendix A - Relevant codes and standards

Australian Building Codes Board (2010) "Building Code of Australia (BCA)" ed., ABCB, Canberra, ACT

Standards-Australia (1999) "HB 132.2:1999 Structural upgrading of older houses: Cyclone areas", Standards Australia, Sydney, NSW

Standards-Australia (2002a) "AS/NZS1170.0:2002 Structural design actions: General principles", Standards Australia, Sydney, NSW.

Standards-Australia (2002b) "AS/NZS 1170.2:2002 Structural design actions: Wind actions", AS/NZS 1170.2:2002, Standards Australia, Sydney NSW, Australia.

Standards Australia (2002c) "AS 2050-2002 Installation of roof tiles", Standards Australia, Sydney, NSW

Standards-Australia (2006) "AS 4055 Wind Loads for Housing", Standards Australia, Sydney, NSW.

Standards Australia (2010) "AS 1684.3:2010 Residential timber-framed construction – Cyclonic areas", Standards Australia, Sydney, NSW, Australia.

Web links:

www.awa.org.au/Industry/Downloads

www.nash.asn.au/nash/publications.html

www.bsadisasterrecovery.qld.gov.au/Contractor/Pages/default.aspx

www.dlqp.qld.gov.au/our-services/building-codes-queensland-2.html

Community Information

There are five ways you can become more resilient to the affects of cyclones:

- Maintain your property.
- If building a new house take note of the recommendations in the Part 1 and 2 Guideline.
- Prepare an evacuation plan for your family.
- Be aware of weather warnings via radios, the internet and mobile phones.
- Create an evacuation kit and an emergency kit.

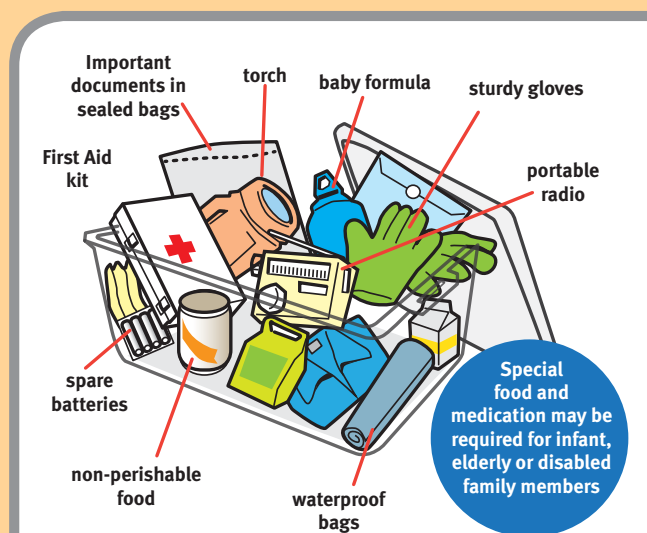

Prepare an Emergency Kit¹

Every family should have a fully stocked Emergency Kit stored safely in their home.

This should include a portable radio, a torch, spare batteries, first aid kit, non-perishable food, sturdy gloves, waterproof bags, candles, matches, essential medications and copies of important documents (eg insurance details, birth certificates, prescription refills) in sealable plastic bags.

¹Reference: www.emergency.qld.gov.au/emq/css/cyclone.asp#emergency_kit

For further information on preparing your home and family visit www.disaster.qld.gov.au

HOUSEHOLD EMERGENCY PLAN

EVACUATION DESTINATION

Place to meet:	
Address:	
Phone number:	
Email address:	

OUT OF TOWN EMERGENCY CONTACT

Name:	
Address:	
Phone number:	
Email address:	

MAIN SERVICE SUPPLIES	LOCATION/SWITCH OFF
Electricity:	
Gas:	
Water:	

VEHICLE REGISTRATION	OUR STRONGEST ROOM IS

MEDICAL CONDITIONS	ESSENTIAL MEDICATION/ DOSAGE

PETS	HOUSEHOLDER SPECIAL NEEDS

EMERGENCY CONTACTS

Life threatening emergencies Police – Fire – Ambulance	Triple Zero (000)
Storm damage and rising flood water - SES	132 500
Local Council	
Doctor/hospital	
Insurance supplier	

EMERGENCY PLAN ACTIVATION

<input type="checkbox"/> Contact all householders	<input type="checkbox"/> Tune into warnings
<input type="checkbox"/> Check on our neighbours	<input type="checkbox"/> Shelter in our strongest room (unless instructed to evacuate)
<input type="checkbox"/> Locate Emergency Kit	<input type="checkbox"/> Make final preparations

EVACUATION CHECKLIST

Prior to evacuation:	
Ensure vehicle is full of fuel	Know the preferred evacuation routes
Know the location of our evacuation meeting place	Check on our neighbours
When evacuating:	
Pack Emergency Kit, Evacuation Kit, a copy of our Emergency Plan, important documents and valuables, medications and water supplies.	Turn off mains supply for power, gas and water
Contact our out of town contact before we leave and once we arrive at our evacuation destination	Secure and local our home and process to our predetermined evacuation destination
If flooding or storm surge is imminent:	
Sandbag internal drains and toilets to prevent backwash	Store electrical items off the ground